

PETITION TO ALTER OR CHANGE A PUBLIC ROAD,
MADISON COUNTY, MISSISSIPPI

TO THE HONORABLE BOARD OF SUPERVISORS OF MADISON COUNTY, MISSISSIPPI





We, the undersigned petitioners, freeholders, and householders of said County respectfully show your honorable body as follows, to-wit:

That the public interest and convenience exists for altering or changing WEST FLORIDA BOULEVARD NORTH, a public road located in Madison County.

The alteration or change to the road meets or exceeds the County's minimum standards for public roads, streets, or byways. The attached exhibit to this petition identifies the proposed alteration or change to be made to WEST FLORIDA BOULEVARD NORTH.

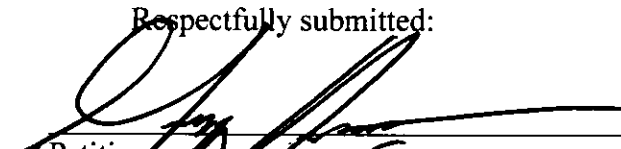
Petitioners, therefore, request the appointment of a committee, according to Mississippi Code 1972 Annotated, Section 65-7-57, who shall examine and view the contemplated route and determine the public interest and convenience.

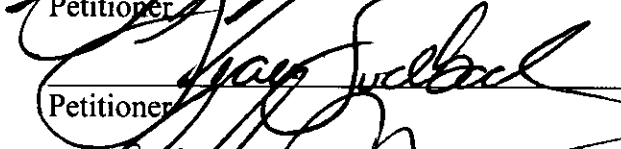
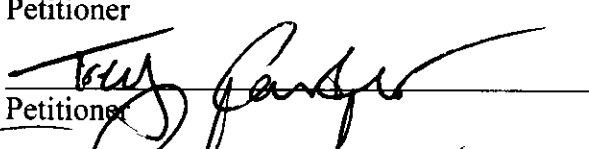
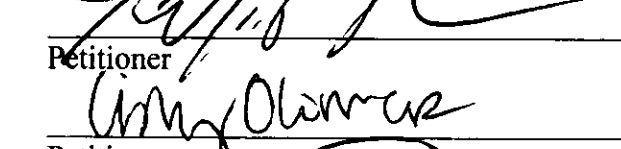
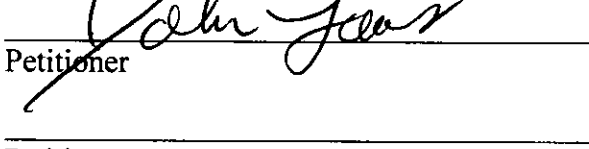
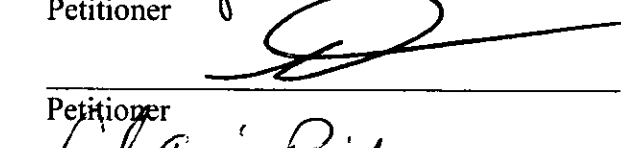
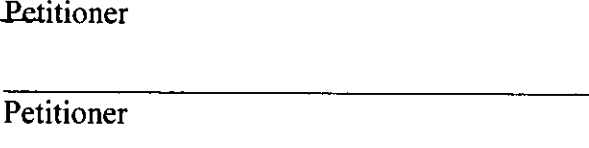
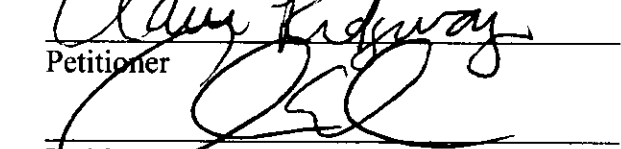
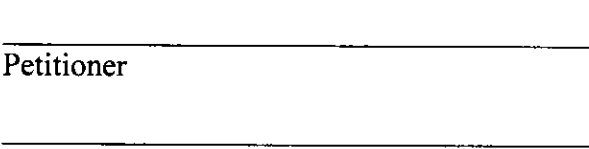
Respectfully submitted:

 _____ Petitioner	 _____ Petitioner
 _____ Petitioner	 _____ Petitioner
 _____ Petitioner	 _____ Petitioner
 _____ Petitioner	 _____ Petitioner
 _____ Petitioner	 _____ Petitioner
 _____ Petitioner	 _____ Petitioner

Witness my signature, this the 10th day of July, 2018.

Subscribing Witness

STATE OF MISSISSIPPI
COUNTY OF MADISON

Personally appeared before me, the undersigned authority in and for the said county and state, on this 10th day of July, 2018, within my jurisdiction, Kenneth McIntosh the subscribing witness to the above and foregoing instrument, who, being first duly sworn, states that (he)(she) saw the above petitioners, whose names are subscribed thereto, sign and deliver the same.
Sworn to and subscribed before me, this the 10th day of July, 2018.

NOTARY PUBLIC

(SEAL)

My Commission Expires:



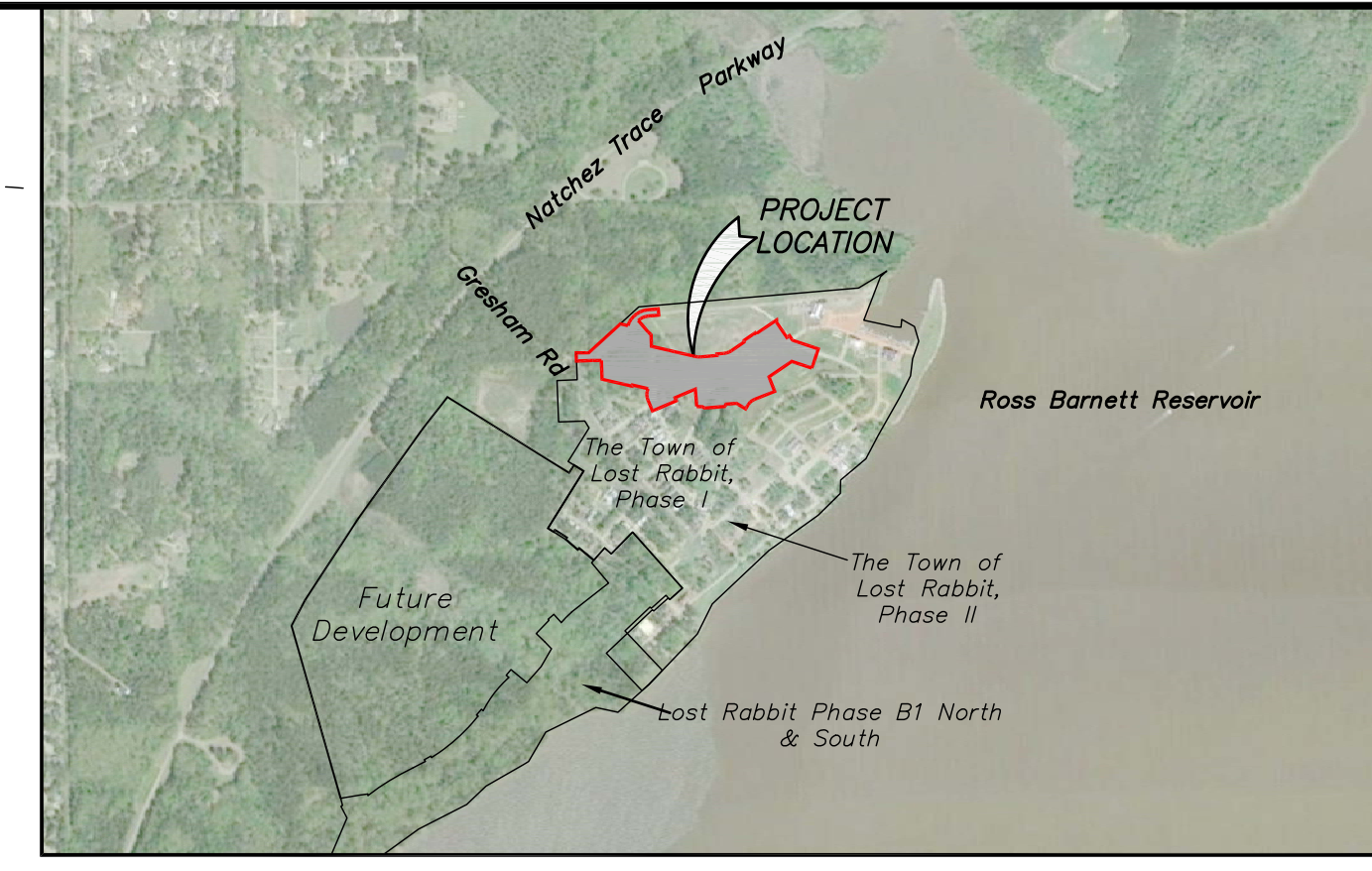

VICINITY MAP
SCALE: 1" = 1,000'

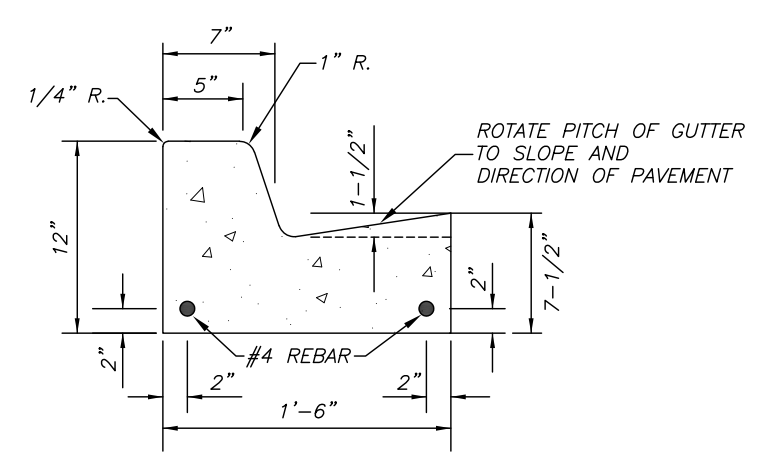
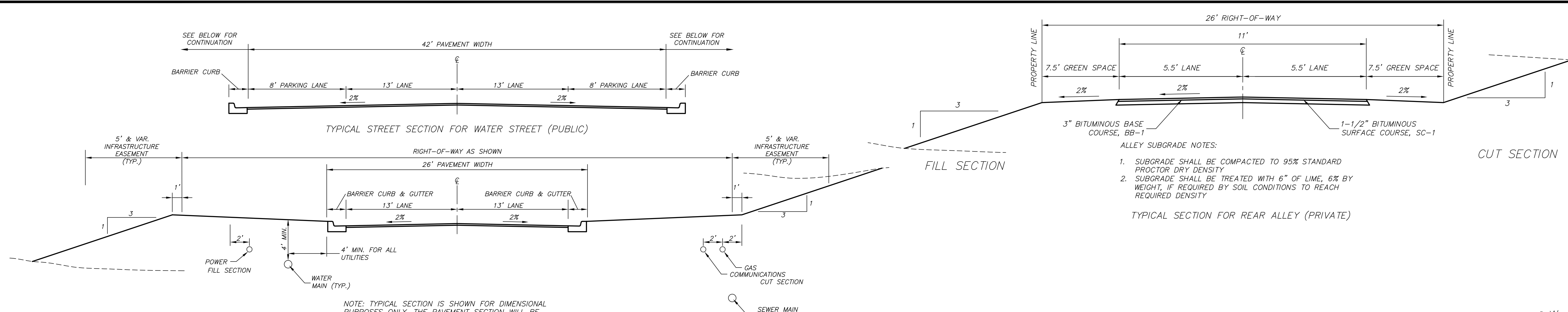

CURB AND GUTTER NOTES:
1. CURB AND GUTTER SHALL BE 3000 PSI MINIMUM CONCRETE.
2. PROVIDE EXPANSION JOINTS WITH 3/4" EXPANSION MATERIAL AT INTERVALS NOT TO EXCEED THIRTY (30') FEET.
3. PROVIDE CONTRACTION JOINTS IN THE CURB AND GUTTER AT INTERVALS NOT TO EXCEED TEN (10') FEET.
4. GUTTER SECTION TO MATCH CROSS SLOPE OF ADJACENT TRAVEL LANE.



NOTES:
DATE OF SURVEY: 7-28-16
ELEVATIONS ARE NAVD88
LOST RABBIT, PHASE IV ACREAGE - ±15.58 ac.
CURRENT ZONING - SU1, SPECIAL USE DISTRICT
TOTAL LOTS - 57
LOCATION, SIZES, AND INVERTS FOR WATER, SEWER & STORM DRAIN INFRASTRUCTURE TO BE DETERMINED DURING PREPARATION OF CONSTRUCTION PLANS SHOULD PRELIMINARY PLAT BE APPROVED.

CLASSIFICATION:
THIS SURVEY MEETS THE REQUIREMENTS OF THE STANDARDS OF PRACTICE FOR SURVEYING IN MISSISSIPPI FOR CLASS B SURVEYS AS ADOPTED BY THE MISSISSIPPI BOARD OF LICENSURE FOR PROFESSIONAL ENGINEERS AND SURVEYORS.
DATE OF FIELD SURVEY: 6-20-16
DEED BOOK 3199, PAGES 986-998
BEARINGS SHOWN HEREON ARE DERIVED FROM PERFORMING GPS OBSERVATIONS AND BASED UPON THE NORTH AMERICAN DATUM 1983 (NAD83), MISSISSIPPI STATE PLANE, GRID COORDINATE SYSTEM, WEST ZONE.
CONVERGENCE ANGLE 00°08'52.2008"
SCALE FACTOR 0.99998268
COMBINED FACTOR 0.999962453

FLOOD NOTE:
THIS PARCEL IS LOCATED IN FLOOD ZONE A & X (NOT SHADED) ACCORDING TO FLOOD INSURANCE RATE MAP NO. 28089C0583F, COMMUNITY PANEL NO. 280339 C585 F, EFFECTIVE DATE MARCH 17, 2010.

LEGEND

---	PHASE BOUNDARY
---	PROP. CURB
---	EX. CURB
---	PROP. EP
---	EX. EP
---	PROP. LOT LINE
---	EX. LOT LINE
---	PROP. R.O.W.
---	EX. R.O.W.
---	EX. ADJACENT PROPERTY LINE

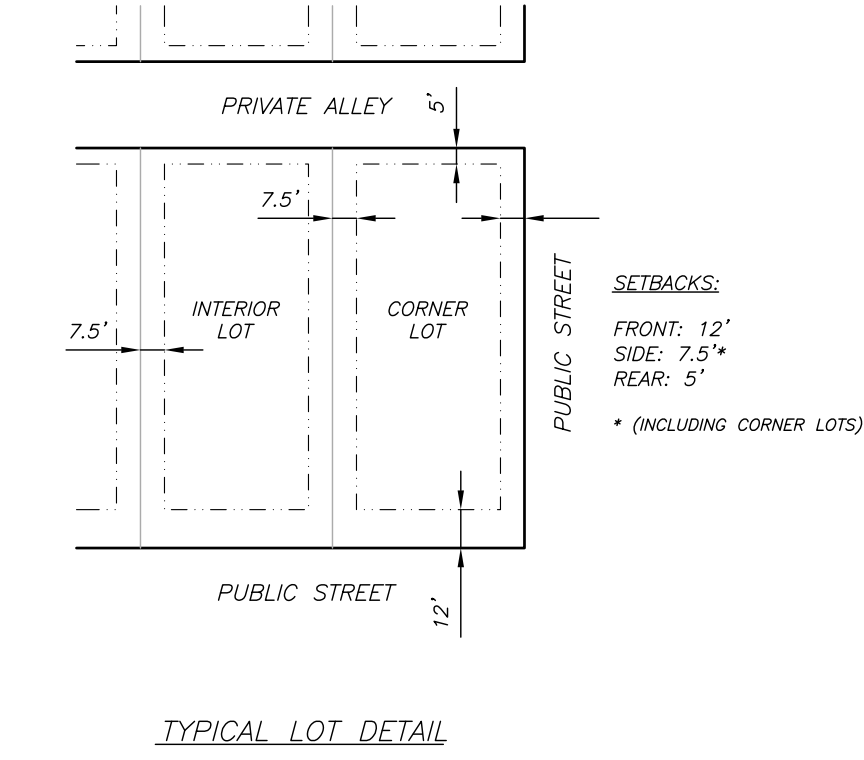
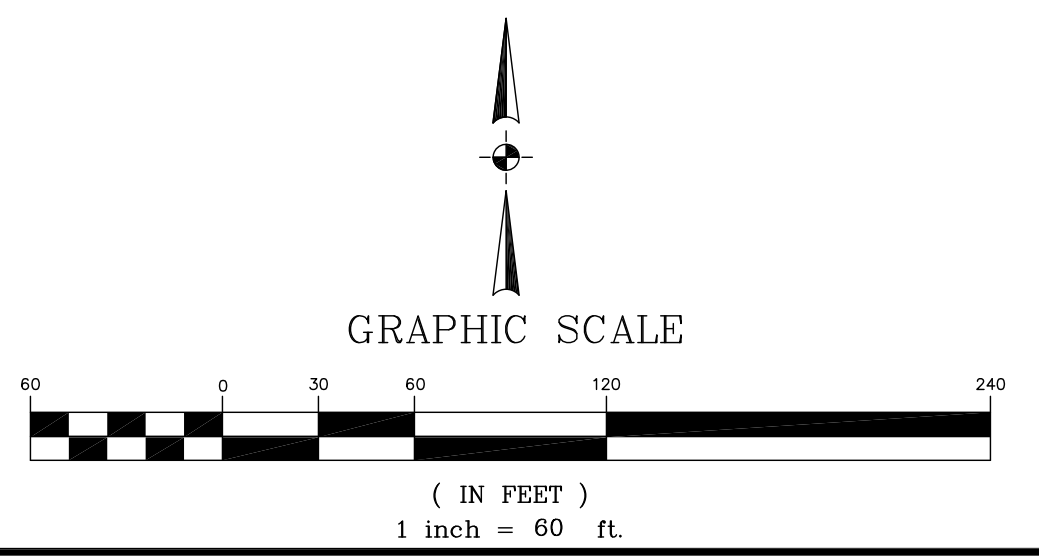

DATE: 03/06/18
DRAWN: BCB
CHECKED: GAB
SCALE: 1" = 60'
REF. C/L:
EG. SURFACE:
FG. SURFACE:

PROJECT LOCATION:
LOST RABBIT COMMUNITY
MADISON COUNTY, MISSISSIPPI
CLIENT:
LUSHOMMI LLC
1100 CAMELLIA BLVD., LAFAYETTE, LA 70508

PROJECT:
LOST RABBIT, PHASE IV
SHEET CONTENTS:
PRELIMINARY LAYOUT
SHEET NUMBER
1
PROJECT NUMBER
B-6408